

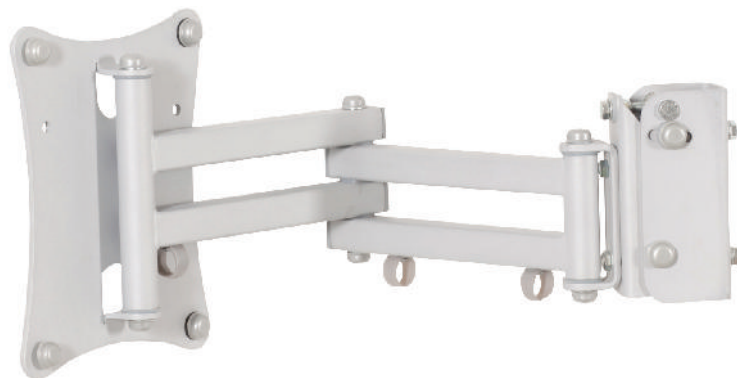

SAL1 ■ Dual Swing Arm Wall Mount 26"-40"



Features

- 1 **ADJUSTABLE POSITION**
3 axes of rotation
- 2 **MAXIMUM LOAD CAPACITY:**
60 Kg
- 3 **QUICK INSTALLATION**
easy installation of the product



Technical Data

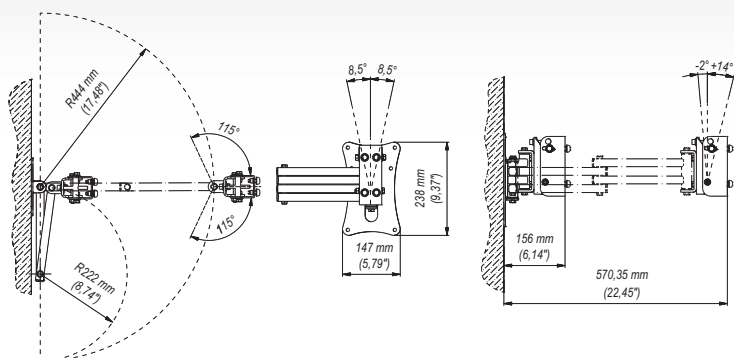

100x100 mm 200x100 mm 200x200 mm 300x300 mm 400x200 mm 400x400 mm 600x400 mm 800x200 mm 800x400 mm	115°/115°	26"-40"	min. 156 mm max. 570,35 mm
-2°/+14°	60 Kg	-8,5°/+8,5°	
			min. 50x75 mm max. 850x460 mm

Trade Information

Index	Colour	Package	EAN
SAL1c-R	■		5908252961290
SAL1c-B	■		5908252960231
SAL1s-R	■		5908252961306
SAL1s-B	■		5908252960248

Package Dimensions [mm] (H x W x D)	670x270x95
Weight [Kg]	4.7

Accessories

LWB1/PWB1/TWB1

